

Vorschweißflansche / Welding Neck Flange EN 1092-1 Typ 11 - PN 40

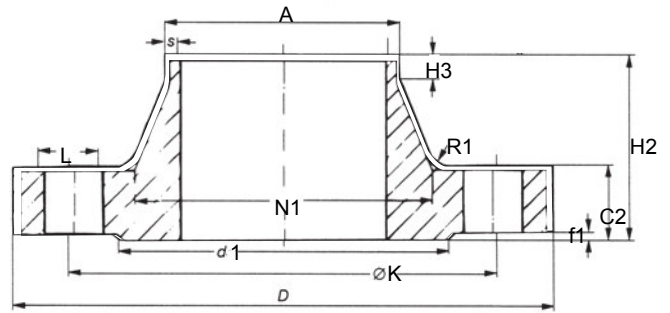

Werkstoff / Material:  
1.4541 / 1.4571  
Dichtfläche Form B



Rohranschluss/ Tube	Flansch/ Flange					Ansatz/ Hub				Dichtleiste/tight groin		Schrauben/ Screws			Gewicht/ weight
	DN	A	D	C2	K	H2	N1	S	R1	H3	d1	f1	Anz.	Gew.	L
10	17,2	90	16	60	35	28	1,8	4	6	40	2	4	M12	14	0,68
15	21,3	95	16	65	38	32	2,0	4	6	45	2	4	M12	14	0,77
20	26,9	105	18	75	40	40	2,3	4	6	58	2	4	M12	14	1,09
25	33,7	115	18	85	40	46	2,6	4	6	68	2	4	M12	14	1,30
32	42,4	140	18	100	42	56	2,6	6	6	78	2	4	M16	18	1,92
40	48,3	150	18	110	45	64	2,6	6	7	88	2	4	M16	18	2,15
50	60,3	165	20	125	48	75	2,9	6	8	102	2	4	M16	18	2,85
65	76,1	185	22	145	52	90	2,9	6	10	122	2	8	M16	18	3,75
80	88,9	200	24	160	58	105	3,2	8	12	138	2	8	M16	18	4,75
100	114,3	235	24	190	65	134	3,6	8	12	162	2	8	M20	22	6,55
125	139,7	270	26	220	68	162	4,0	8	12	188	2	8	M24	26	9,00
150	168,3	300	28	250	75	192	4,5	10	12	218	2	8	M24	26	11,70
200	219,1	375	34	320	88	244	6,3	10	16	285	2	12	M27	30	21,00
250	273,0	450	38	385	105	306	7,1	12	18	345	2	12	M30	33	34,00
300	323,9	515	42	450	115	362	8,0	12	18	410	2	16	M30	33	47,50
350	355,6	580	46	510	125	408	8,8	12	20	465	2	16	M33	36	69,00
400	406,4	660	50	585	135	462	11,0	12	20	535	2	16	M36	39	98,00
450	457,0	685	57	610	135	500	12,5	12	20	560	2	20	M36	39	105,00
500	508,0	755	57	670	140	562	14,2	12	20	615	2	20	M39	42	130,50
600	610,0	890	72	795	150	666	16,0	12	20	735	2	20	M45	48	210,00