

Vorschweißflansche / Welding Neck Flange EN 1092-1 Typ 11 - PN 10

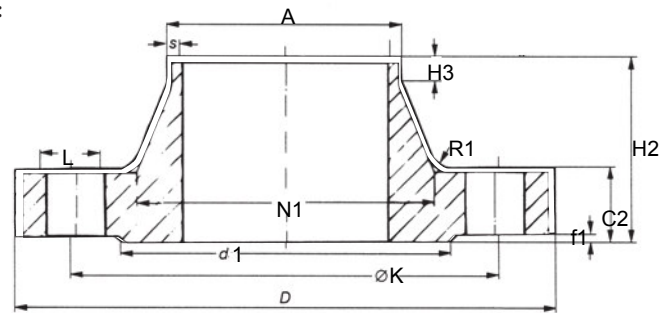

Werkstoff / Material:  
1.4541 / 1.4571  
Dichtfläche Form B



DN	A	D	C2	K	H2	N1	S	R1	H3	d1	f	anz	gew	L	kg
10											1				
15															
20															siehe Maße PN 40
25															
32															
40															
50															
65															
80															siehe Maße PN 16
100															
125															
150															
200	219,1	340	24	295	62	234	6,3	10	16	268	2	8	M20	22	11,50
250	273,0	395	26	350	68	292	6,3	12	16	320	2	12	M20	22	15,50
300	323,9	445	26	400	68	342	7,1	12	16	370	2	12	M20	22	18,00
350	355,6	505	26	460	68	385	7,1	12	16	430	2	16	M20	22	24,50
400	406,4	565	26	515	72	440	7,1	12	16	482	2	16	M24	26	29,50
450	457,0	615	28	565	72	488	7,1	12	16	532	2	20	M24	26	34,00
500	508,0	670	28	620	75	542	7,1	12	16	585	2	20	M24	26	39,50
600	610,0	780	28	725	80	642	7,1	12	18	685	2	20	M27	30	56,00
700	711,0	895	30	840	80	746	8,0	12	18	800	2	24	M27	30	65,00
800	813,0	1015	32	950	90	850	8,0	12	18	905	2	24	M30	33	87,00
900	914,0	1115	34	1050	95	950	10,0	12	20	1005	2	28	M30	33	106,00
1000	1016,0	1230	34	1160	95	1052	10,0	16	20	1110	2	28	M33	36	123,00